

THIS DRAWING IS UNPUBLISHED. RELEASED FOR PUBLICATION
 © COPYRIGHT BY TYCO ELECTRONICS CORPORATION. ALL RIGHTS RESERVED.

LOC	DIST	REVISIONS					
FT	0	P	LTR	DESCRIPTION	DATE	DWN	APVD
			C	REVISED PER ECO-08-010814	15MAY08	HMR	MZ

MATERIAL:
 HOUSING: THERMOPLASTIC, UL94V-0, BLACK
 TERMINALS: BRIGHT TIN PLATED COPPER ALLOY
 SCREWS: 8-32, ZINC PLATED STEEL.

ELECTRICAL PROPERTIES:
 CURRENT RATING: 30A
 VOLTAGE RATING: 600V
 WIRE RANGE: 10-18 AWG (UL)
 10-22 AWG (CSA)

MECHANICAL:
 RECOMMENDED TORQUE: 20 IN-LB.
 OPERATING TEMP.: -40°C TO +120°C

1 MARKED WITH WITH WHITE INK APPROX. AS SHOWN.

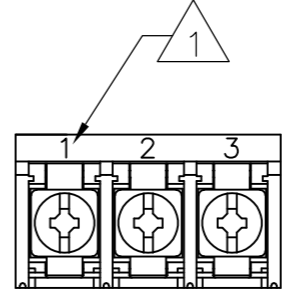
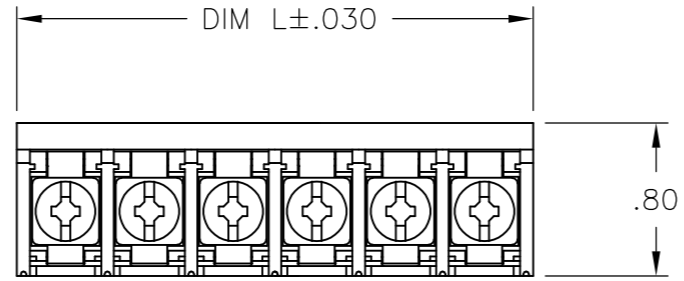

1-1546160-1

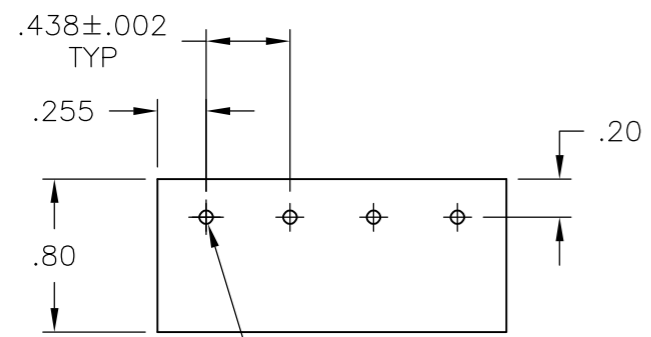
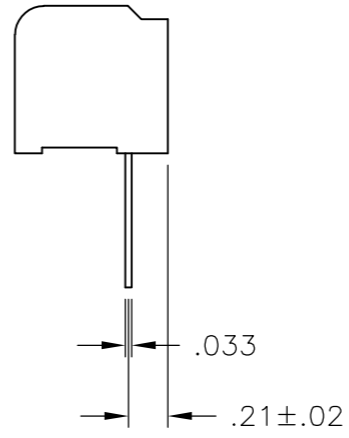
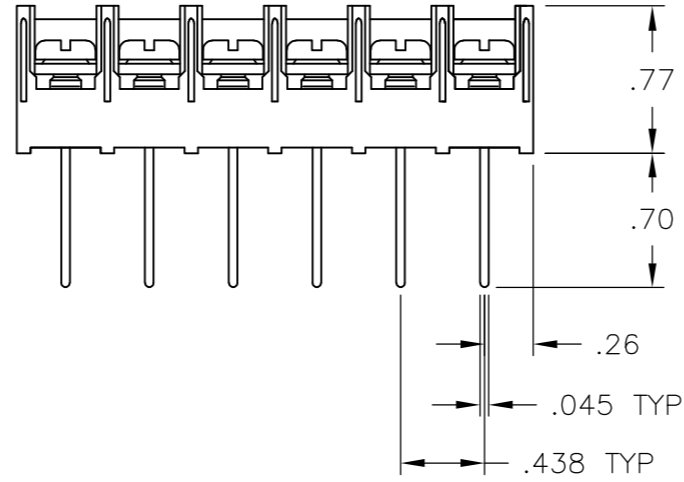

RECOMMENDED PCB LAYOUT

DIM L	NO OF POS	CATALOG NUMBER	PART NUMBER
8.823	20	8WWV-20-008	1-1546160-4
8.385	19	8WWV-19-008	1-1546845-9
7.948	18	8WWV-18-008	1-1546845-8
7.510	17	8WWV-17-008	1-1546845-7
7.073	16	8WWV-16-008	1-1546845-6
6.635	15	8WWV-15-008	1-1546845-5
6.198	14	8WWV-14-008	1-1546845-4
5.760	13	8WWV-13-008	796616-5
5.323	12	8WWV-12-008	1-1546845-2
4.885	11	8WWV-11-008	1-1546845-1
4.448	10	8WWV-10-008	1-1546845-0
4.010	9	8WWV-09-008	1546845-9
3.573	8	8WWV-08-008	1546845-8
3.135	7	8WWV-07-008	1546845-7
2.698	6	8WWV-06-008	1546845-6
2.260	5	8WWV-05-008	9-1437659-0
1.823	4	8WWV-04-008	1-1546160-2
1.385	3	8WWV-03-579	1-1546160-1
1.385	3	8WWV-03-008	1546845-3
.948	2	8WWV-02-008	796616-9

SEE FIGURE

THIS DRAWING IS A CONTROLLED DOCUMENT.		DWN S SCHLEGEL 11/15/06	Tyco Electronics Corporation Harrisburg, PA 17105-3608	
DIMENSIONS: INCHES		CHK S YODER 11/15/06		
TOLERANCES UNLESS OTHERWISE SPECIFIED:		APVD S YODER 11/15/06	NAME	
0 PLC ± - 1 PLC ± - 2 PLC ± .01 3 PLC ± .005 4 PLC ± - ± 1' ANGLES ± 1'		PRODUCT SPEC -	8WWV-XX-008 ASSEMBLY	
MATERIAL -		FINISH -	APPLICATION SPEC -	RESTRICTED TO -
		WEIGHT -	SIZE A3	CAGE CODE 00779
		CUSTOMER DRAWING	DRAWING NO C-9-1437659-0	
		SCALE 1:1	SHEET 1 OF 1	REV C